

IP65 On/off PIR Motion Sensor (High-bay)

WSEL380 Czujnik PIR RC HYT PIR ON/OFF IP65 HC049S IoT



Product Description

HC049S is a high-bay PIR on/off motion sensor, with capability of up to 15m installation height. HC049S has a daylight sensor built-in, and is specifically designed for mounting onto a batten style luminaire. All sensor parameters can be programmed through remote controller HRC-11.



Features

IP65

Max withstandable in-rush current: 80A@160μs

Black & White & Gray metal surface mount box option

Fixing washers accessory

High-bay (up to 15m height)

Remote controllable

5-year warranty

Technical Specifications

Input Characteristics	
Operating voltage	220 ~ 240VAC 50/60Hz
Stand-by power	<0.5W
Load ratings	400VA (capacitive) 800W (resistive)
Max withstandable in-rush current	80A@160μs
Warming-up	30s
Sensitivity	10% / 30% / 50% / 75% / 100

Safety and EMC	
EMC standard (EMC)	EN55015, EN61547 EN61000-3-21-3-3
Safety standard (LVD)	EN61347-1, EN61347-2-11
Certification	ENEC, CE, EMC, LVD, RCM

Sensor Data	
Sensor principle	PIR detection
Detection range*	Max installation height: 12m Max detection range: 10m
Detection angle	360°

* The detection range is heavily influenced by sensor placement (angle) and different walking paces. It may be reduced under certain conditions.

Environment	
Operation temperature*	Ta: -20°C ~ +50°C
Storage temperature	-35°C ~ +55°C
Relative humidity	20 ~ 90%
IP rating	IP65
Insulation	Class II

* When used in -35°C ~ -20°C environment, the sensor still functions but the detection range & life-span would be compromised. The optimal Ta would be -20°C ~ +50°C and we apply 5-year guarantee for such usage condition.

Zero-cross Relay Operation

The sensor switches on/off the load right at the zero-cross point, to ensure that the in-rush current is minimised, enabling the maximum lifetime of the relay.

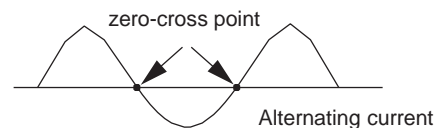

Mechanical Structure & Dimensions

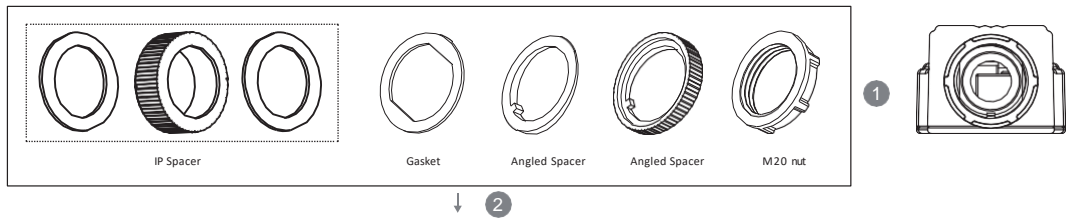
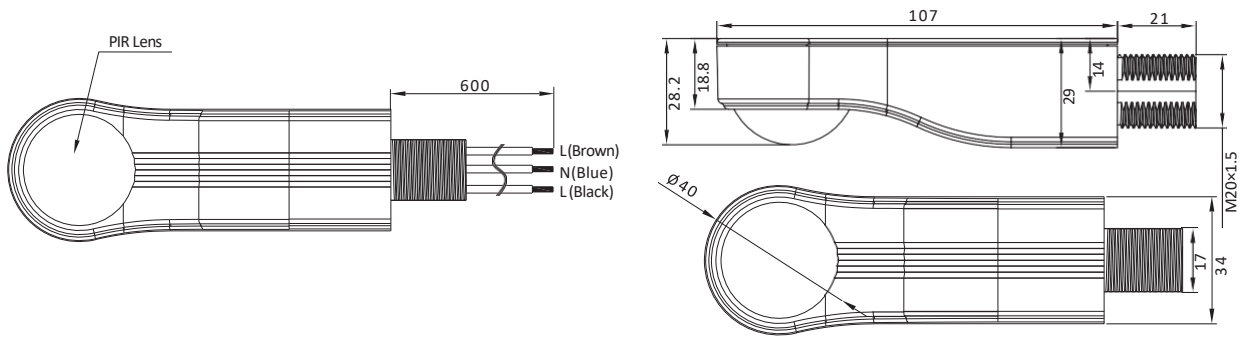

Typical Installation 1

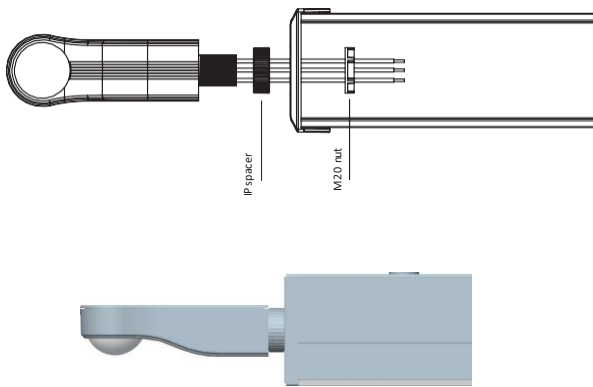

Typical Installation 2

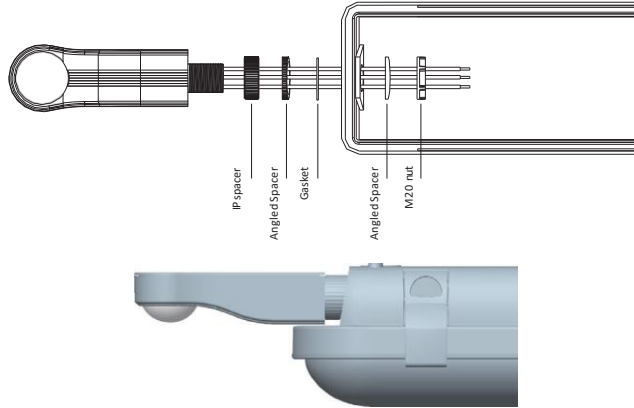

Wiring Diagram

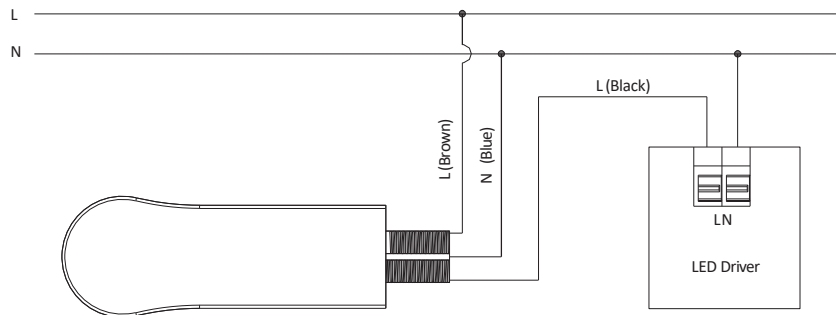

Shielding Accessory

For the application of limited coverage areas (hallways), the line pattern of the shielding accessory can be freely removed by cutting to achieve a different range of shielding induction, for example, rectangular detection and semi-sphere detection. The portable design also provides an easy installation, which only needs to buckle the shielding accessory onto the lens.

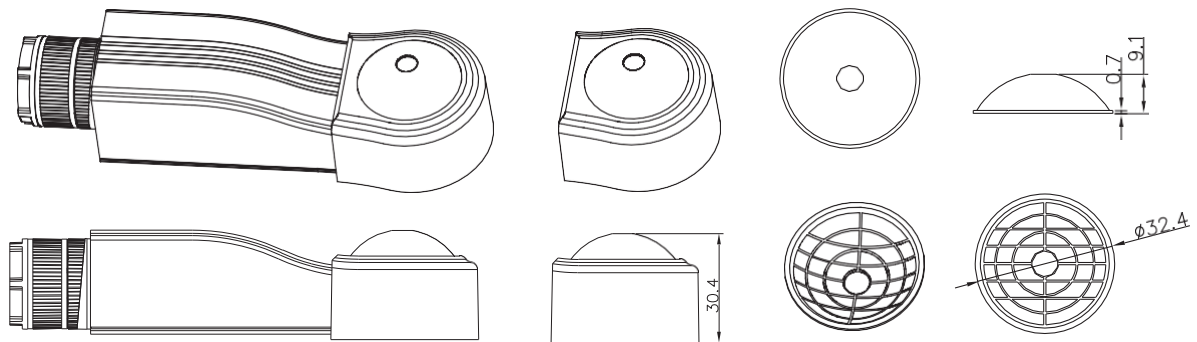

Detection Pattern

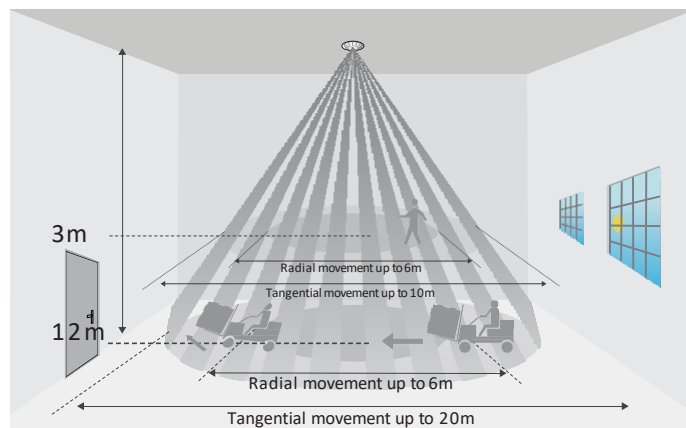

*The detection patterns are based upon 5km/h movement speed.

On/Off Control

This sensor is a motion switch, which turns on the light upon detection of motion, and turns off after a pre-selected hold-time when there is no movement. A daylight sensor is also built in to prevent the light from switching on when there is sufficient natural light.



With sufficient natural light, the light does not switch on when presence is detected.

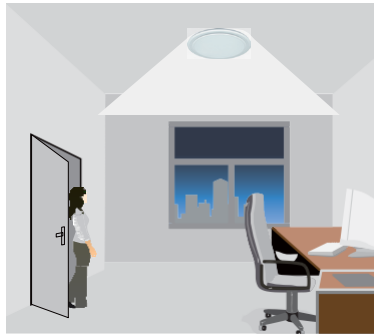

With insufficient natural light, the sensor switches on the light automatically when presence is detected.



The sensor switches off the light automatically after the hold-time when there is no motion detected.

For more information, contact iot@lenalighting.pl